

Exam, 2012-2013 Solutions

Note that many of the answers are more detailed than is required for “full credit”

Do a total of 12 points or any four complete questions. Show your work!

Q1: 5 parts/5 points, no dependencies

Q2: 3 parts/3 points, no dependencies

Q3: 3 parts/3 points, parts B and C depend on A

Q4: 2 parts/2 points, no dependencies

Q5: 2 parts/2 points, part B depends on A

Q6: 2 parts/3 points, part B (one point) depends on A (two points) [revised]

Q1. Semidirect products (5 parts, 1 point for each part)

Here we define the “semi-direct product,” a standard way of building larger groups from smaller ones. Let H and K be groups, with a homomorphism from K into the automorphism group of H . That is, for each element $k \in K$, there is an automorphism α_k of H , and $\alpha_k \alpha_{k'} = \alpha_{kk'}$.

With this setup, we can define an operation on (h, k) pairs: $(h, k) \circ (h', k') = (h\alpha_k(h'), kk')$, where the composition $h\alpha_k(h')$ takes place in H , and the composition kk' takes place in K .

A. Show that this operation forms a group, known as the “semidirect product of H and K ”.

Identity: The pair formed from the identity elements of H and K , (e_H, e_K) , is the identity:

$(e_H, e_K) \circ (h, k) = (e_H \alpha_{e_K}(h), e_K k) = (e_H h, e_K k) = (h, k)$, where the second equality uses the fact that the mapping from k to α_k is a homomorphism, so the identity e_K must map to the identity automorphism.
 $(h, k) \circ (e_H, e_K) = (h\alpha_k(e_H), ke_K) = (he_H, e_K k) = (h, k)$, where the second equality uses the fact that α_k is an automorphism of H .

Associative law: This requires equality between

$((h, k) \circ (h', k')) \circ (h'', k'') = (h\alpha_k(h'), kk') \circ (h'', k'') = (h\alpha_k(h')\alpha_{kk'}(h''), kk'k'')$ and

$(h, k) \circ ((h', k') \circ (h'', k'')) = (h, k) \circ (h'\alpha_{k'}(h''), k'k'') = (h\alpha_k(h'\alpha_{k'}(h'')), kk'k'')$, so it must be verified that the first components of the final left sides must match:

$h\alpha_k(h'\alpha_{k'}(h'')) = h\alpha_k(h')\alpha_k(\alpha_{k'}(h'')) = h\alpha_k(h')\alpha_{kk'}(h'')$, where the first equality makes use of the fact that α_k is an automorphism of H , and the second uses of the fact that the mapping from k to α_k is a homomorphism.

Inverse: The inverse of (h, k) is $(\alpha_k^{-1}(h^{-1}), k^{-1})$, since

$(h, k) \circ (\alpha_k^{-1}(h^{-1}), k^{-1}) = (h\alpha_k(\alpha_k^{-1}(h^{-1})), kk^{-1}) = (hh^{-1}, kk^{-1}) = (e_H, e_K)$. As a check:

$(\alpha_k^{-1}(h^{-1}), k^{-1}) \circ (h, k) = (\alpha_k^{-1}(h^{-1})\alpha_{k^{-1}}(h), k^{-1}k) = (\alpha_k^{-1}(h^{-1})\alpha_k^{-1}(h), kk^{-1}) = (\alpha_k^{-1}(h^{-1}h), e_K) = (e_H, e_K)$, where the second equality uses the fact that the mapping from k to α_k is a homomorphism (so $\alpha_{k^{-1}} = \alpha_k^{-1}$), and the third equality uses the fact that α_k^{-1} is an automorphism of H .

B. Recall the definition of a normal subgroup: A subgroup N of G is said to be a “normal” subgroup if, for any element g of G and any element n of N , the combination gng^{-1} is also a member of N .

Determine whether the set of elements $S_K = \{(e_H, k)\}$ is a normal subgroup.

With $n = (e_H, k')$, $g = (h, k)$, and $g^{-1} = (\alpha_k^{-1}(h^{-1}), k^{-1})$, we have

$$\begin{aligned} gng^{-1} &= ((h, k) \circ (e_H, k')) \circ (\alpha_k^{-1}(h^{-1}), k^{-1}) \\ &= (h\alpha_k(e_H), kk') \circ (\alpha_k^{-1}(h^{-1}), k^{-1}) \\ &= (h, kk') \circ (\alpha_k^{-1}(h^{-1}), k^{-1}) \\ &= (h\alpha_{kk'}(\alpha_k^{-1}(h^{-1})), kk'k^{-1}) \\ &= (h\alpha_{kk'k^{-1}}(h^{-1}), kk'k^{-1}) \end{aligned}$$

The first element is only the identity if

$h\alpha_{kk'k^{-1}}(h^{-1}) = e_H$ which in turn requires that $\alpha_{kk'k^{-1}}(h^{-1}) = h^{-1}$. If this were true for all h , then $\alpha_{kk'k^{-1}}$ would be the identity automorphism for all k and k' . Thus, unless one is dealing with a “trivial” semidirect product (one in which all automorphisms α_k are the identity), $S_K = \{(e_H, k)\}$ is not a normal subgroup.

C. Determine whether the set of elements $S_H = \{(h, e_K)\}$ is a normal subgroup.

With $n = (h', e_K)$, $g = (h, k)$, and $g^{-1} = (\alpha_k^{-1}(h^{-1}), k^{-1})$, we have

$$\begin{aligned} gng^{-1} &= ((h, k) \circ (h', e_K)) \circ (\alpha_k^{-1}(h^{-1}), k^{-1}) \\ &= (h\alpha_k(h'), ke_K) \circ (\alpha_k^{-1}(h^{-1}), k^{-1}) \\ &= (h\alpha_k(h'), k) \circ (\alpha_k^{-1}(h^{-1}), k^{-1}) \\ &= (h\alpha_k(h')\alpha_k(\alpha_k^{-1}(h^{-1})), kk^{-1}) \\ &= (h\alpha_k(h')h^{-1}, e_K) \end{aligned}$$

The last quantity is a member of S_H .

We also have to check that S_H itself is a group under \circ . This holds because within S_H , the group operation \circ is the same as the group operation in H : $(h, e_K) \circ (h', e_K) = (h\alpha_{e_K}(h'), e_K) = (hh', e_K)$. Note that α_{e_K} must be the identity automorphism, since e_K is the identity in K , and the mapping from k to α_k is a homomorphism.

Since S_H is a group, and conjugation by any g stays within S_H , S_H is a normal subgroup.

D. Use the above construction to create a continuous non-commutative group, where H and K are both commutative.

Let H be the group of real numbers under addition, and K be the group of non-zero real numbers, under multiplication. Let $\alpha_k(h) = kh$.

Note that the resulting group is the group of affine transformations, $T_{(h,k)}(x) = kx + h$.

$$(T_{(h,k)} \circ T_{(h',k')})(x) = T_{(h,k)}(T_{(h',k')}(x)) = T_{(h,k)}(k'x + h') = k(k'x + h') + h = kk'x + (kh' + h) = T_{(h,k) \circ (h',k')}(x).$$

E. Use the above construction to create a discrete non-commutative group that is of size 21.

Since the target group is of size 21, the sizes of H and K must necessarily be 3 and 7 (in either order). The group of size 3 has only two automorphisms, the trivial one and $g \rightarrow g^{-1}$ (since there are only two elements that are not the identity). So the three-element group cannot be H , since then we'd need to find a nontrivial homomorphism of the 7-element group into the group of its two automorphisms. Taking alternatively H to be the 7-element group, i.e., $H = \{e, h, h^2, \dots, h^6\}$, we note that it has six nontrivial automorphisms, each described by $h \rightarrow h^r$ for $r \in \{1, \dots, 6\}$. Composition of automorphisms corresponds to multiplication of the exponents (mod 7). So a three-element subgroup of these automorphisms corresponds to $r \in \{1, 2, 4\}$, i.e., the trivial automorphism, and the automorphisms are $q: h \rightarrow h^2$ and $q^2: h \rightarrow h^4$. So we take $K = \{e_k, k, k^2\}$ (with $k^3 = 1$), and $\alpha_k = q$, $\alpha_{k^2} = q^2$

Q2. Operator exponentials (3 parts, 1 point for each part)

Setup: A is a Hermitian operator; s and t are complex numbers. Define $e^{As} = \sum_{k=0}^{\infty} \frac{1}{k!} s^k A^k$, where A^k indicates (ordinary) repetitive application of the operator A (and $A^0 = I$).

A. Is $e^{A(s+t)} = e^{As} e^{At}$? Why or why not?

We need to show that $e^{A(s+t)}v = e^{As} e^{At}v$ for every vector v .

Since A is Hermitian, its eigenvectors φ_i (for which $A\varphi_i = \lambda_i\varphi_i$) form a basis, and we can write

$v = \sum a_i \varphi_i$. So $A^k v = A^k \left(\sum a_i \varphi_i \right) = \sum a_i A^k \varphi_i = \sum a_i \lambda_i^k \varphi_i$, and

$$e^{As}v = \sum_{k=0}^{\infty} \frac{1}{k!} s^k A^k v = \sum_{k=0}^{\infty} \frac{1}{k!} s^k \left(\sum_i a_i \lambda_i^k \varphi_i \right) = \sum_i a_i \sum_{k=0}^{\infty} \frac{1}{k!} s^k \lambda_i^k \varphi_i = \sum_i a_i e^{s\lambda_i} \varphi_i.$$

So e^{As} acts in each eigenspace as multiplication by $e^{s\lambda_i}$.

Similarly, e^{At} acts in each eigenspace as multiplication by $e^{t\lambda_i}$.

The composition $e^{As} e^{At}$ acts in each eigenspace as sequential multiplication by both factors, and, since $e^{s\lambda_i} e^{t\lambda_i} = e^{(s+t)\lambda_i}$ as ordinary scalars, it follows that $e^{A(s+t)}v = e^{As} e^{At}v$ for every vector v .

B. Is $e^{(A+B)s} = e^{As} e^{Bs}$? Why or why not?

One could just try it for some generic A and B , and find that it fails. Or, one could look at the lowest-order terms:

$$e^{(A+B)s} = I + (A+B)s + \frac{1}{2}(A+B)^2 s^2 + O(s^3), \text{ and}$$

$$e^{As} e^{Bs} = \left(I + As + \frac{1}{2}A^2 s^2 \right) \left(I + Bs + \frac{1}{2}B^2 s^2 \right) + O(s^3) = I + As + Bs + \left(AB + \frac{1}{2}A^2 + \frac{1}{2}B^2 \right) s^2 + O(s^3).$$

For equality to hold, there must be agreement of the coefficients at each power of s . For s^2 , this requires

$$\frac{1}{2}(A+B)^2 = AB + \frac{1}{2}A^2 + \frac{1}{2}B^2, \text{ which is equivalent to } \frac{1}{2}(A^2 + B^2 + AB + BA) = AB + \frac{1}{2}A^2 + \frac{1}{2}B^2, \text{ and}$$

to $AB = BA$. So unless A and B commute, $e^{(A+B)s} \neq e^{As} e^{Bs}$. (Conversely, one can show that if $AB = BA$, then equality holds – without the need to assume that A or B have a full set of eigenvectors.)

C. What is $\det(e^A)$ in terms of the coefficients of the characteristic equation for A ?

$\det(e^A)$ is the product of the eigenvalues of e^A . The eigenvalues of e^A are e^{λ_i} , where the λ_i are the

eigenvalues of A . (See part A or class notes). So $\det(e^A) = e^{\sum_i \lambda_i} = e^{\text{tr}(A)}$.

Q3. Transfer functions and power spectra (3 parts, 1 point for each part)

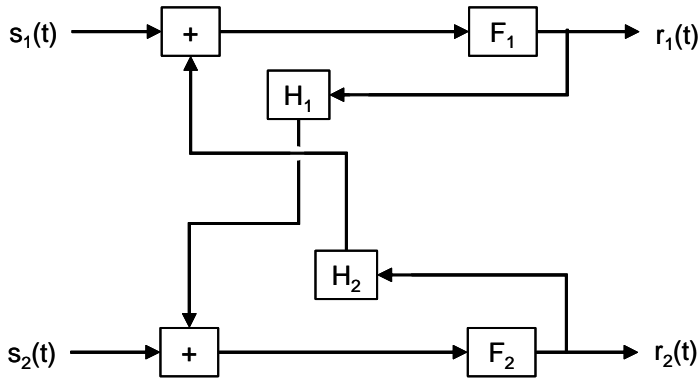

The boxes are linear filters, with transfer functions $\tilde{F}_i(\omega)$ and $\tilde{H}_i(\omega)$.

A. Determine the relationships between the Fourier transforms of the inputs $\tilde{s}_i(\omega)$ and the outputs $\tilde{r}_i(\omega)$.

Considering the input-output relationship for F_1 : $\tilde{r}_1(\omega) = \tilde{F}_1(\omega) (\tilde{s}_1(\omega) + \tilde{H}_2(\omega)\tilde{r}_2(\omega))$.

Considering the input-output relationship for F_2 : $\tilde{r}_2(\omega) = \tilde{F}_2(\omega) (\tilde{s}_2(\omega) + \tilde{H}_1(\omega)\tilde{r}_1(\omega))$.

Combining,

$$\begin{aligned} \tilde{r}_1(\omega) &= \tilde{F}_1(\omega) (\tilde{s}_1(\omega) + \tilde{H}_2(\omega)\tilde{r}_2(\omega)) \\ &= \tilde{F}_1(\omega) (\tilde{s}_1(\omega) + \tilde{H}_2(\omega) (\tilde{F}_2(\omega) (\tilde{s}_2(\omega) + \tilde{H}_1(\omega)\tilde{r}_1(\omega)))) \\ &= \tilde{F}_1(\omega) (\tilde{s}_1(\omega) + \tilde{H}_2(\omega)\tilde{F}_2(\omega)\tilde{s}_2(\omega) + \tilde{F}_2(\omega)\tilde{H}_1(\omega)\tilde{H}_2(\omega)\tilde{r}_1(\omega)) \end{aligned}$$

which implies

$$\tilde{r}_1(\omega) = \frac{\tilde{F}_1(\omega)}{1 - \tilde{F}_1(\omega)\tilde{F}_2(\omega)\tilde{H}_1(\omega)\tilde{H}_2(\omega)} (\tilde{s}_1(\omega) + \tilde{F}_2(\omega)\tilde{H}_2(\omega)\tilde{s}_2(\omega)).$$

Similarly,

$$\tilde{r}_2(\omega) = \frac{\tilde{F}_2(\omega)}{1 - \tilde{F}_1(\omega)\tilde{F}_2(\omega)\tilde{H}_1(\omega)\tilde{H}_2(\omega)} (\tilde{s}_2(\omega) + \tilde{F}_1(\omega)\tilde{H}_1(\omega)\tilde{s}_1(\omega)).$$

B. Suppose that $s_1(t)$ and $s_2(t)$ are Gaussian noises, whose power spectra are $P_1(\omega)$ and $P_2(\omega)$.

Assuming they are independent, calculate the power spectra of $r_1(t)$ and $r_2(t)$, and the cross-spectrum of $r_1(t)$ and $r_2(t)$.

We calculate using Fourier estimates:

$$E(r_i, \omega) = E(r_i, \omega, T, T_0) = \int_T^{T+T_0} r_i(t) e^{-i\omega t} dt, \text{ so that the power spectrum of } r_i \text{ is given by}$$

$$R_i(\omega) = \lim_{T \rightarrow \infty} \frac{1}{T} \langle |E(r_i, \omega)|^2 \rangle \text{ and the cross-spectrum is given by } R_{12}(\omega) = \lim_{T \rightarrow \infty} \frac{1}{T} \langle E(r_1, \omega) \overline{E(r_2, \omega)} \rangle.$$

The distributions of the Fourier estimates of the inputs are determined by their power spectra:

$P_i(\omega) = \lim_{T \rightarrow \infty} \frac{1}{T} \langle |E(s_i, \omega)|^2 \rangle$, and, according to the hypothesis that the inputs are independent, $\langle E(s_1, \omega) \overline{E(s_2, \omega)} \rangle = 0$.

We use the results of part A to relate the Fourier estimates of the outputs $r_i(t)$ to the Fourier estimates of the inputs $s_i(t)$. For convenience, take $\tilde{L}(\omega) = \frac{1}{1 - \tilde{F}_1(\omega)\tilde{F}_2(\omega)\tilde{H}_1(\omega)\tilde{H}_2(\omega)}$.

From

$$\tilde{r}_1(\omega) = \tilde{Z}(\omega)\tilde{F}_1(\omega)(\tilde{s}_1(\omega) + \tilde{F}_2(\omega)\tilde{H}_2(\omega)\tilde{s}_2(\omega)),$$
 it follows that

$$E(r_1, \omega) = \tilde{Z}(\omega)\tilde{F}_1(\omega)(E(s_1, \omega) + \tilde{F}_2(\omega)\tilde{H}_2(\omega)E(s_2, \omega)),$$
 and similarly

$$E(r_2, \omega) = \tilde{Z}(\omega)\tilde{F}_2(\omega)(E(s_2, \omega) + \tilde{F}_1(\omega)\tilde{H}_1(\omega)E(s_1, \omega)).$$

So

$$\langle |E(r_1, \omega)|^2 \rangle = |\tilde{Z}(\omega)\tilde{F}_1(\omega)|^2 \left(\langle |E(s_1, \omega)|^2 \rangle + |\tilde{F}_2(\omega)\tilde{H}_2(\omega)|^2 \langle |E(s_2, \omega)|^2 \rangle \right)$$

Note that the cross-term $\langle E(s_1, \omega) \overline{E(s_2, \omega)} \rangle$ vanishes, since we have assumed that $s_1(t)$ and $s_2(t)$ are independent. The relationship between spectral estimates and power spectra yields:

$$R_1(\omega) = \lim_{T \rightarrow \infty} \frac{1}{T} \langle |E(r_1, \omega)|^2 \rangle = |\tilde{Z}(\omega)\tilde{F}_1(\omega)|^2 \left(P_1(\omega) + |\tilde{F}_2(\omega)\tilde{H}_2(\omega)|^2 P_2(\omega) \right),$$
 and, symmetrically,

$$R_2(\omega) = \lim_{T \rightarrow \infty} \frac{1}{T} \langle |E(r_2, \omega)|^2 \rangle = |\tilde{Z}(\omega)\tilde{F}_2(\omega)|^2 \left(P_2(\omega) + |\tilde{F}_1(\omega)\tilde{H}_1(\omega)|^2 P_1(\omega) \right).$$

For the cross-spectra:

$$\langle E(r_1, \omega) \overline{E(r_2, \omega)} \rangle =$$

$$|\tilde{Z}(\omega)|^2 \tilde{F}_1(\omega)\tilde{F}_2(\omega) \left\langle \left(E(s_1, \omega) + \tilde{F}_2(\omega)\tilde{H}_2(\omega)E(s_2, \omega) \right) \overline{\left(E(s_2, \omega) + \tilde{F}_1(\omega)\tilde{H}_1(\omega)E(s_1, \omega) \right)} \right\rangle.$$

Since the cross-term $\langle E(s_1, \omega) \overline{E(s_2, \omega)} \rangle$ is zero,

$$\langle E(r_1, \omega) \overline{E(r_2, \omega)} \rangle = |\tilde{Z}(\omega)|^2 \tilde{F}_1(\omega)\tilde{F}_2(\omega) \left(\tilde{F}_1(\omega)\tilde{H}_1(\omega) \langle |E(s_1, \omega)|^2 \rangle + \tilde{F}_2(\omega)\tilde{H}_2(\omega) \langle |E(s_2, \omega)|^2 \rangle \right),$$

So

$$R_{12}(\omega) = \lim_{T \rightarrow \infty} \frac{1}{T} \langle E(r_1, \omega) \overline{E(r_2, \omega)} \rangle = |\tilde{Z}(\omega)|^2 \tilde{F}_1(\omega)\tilde{F}_2(\omega) \left(\tilde{F}_1(\omega)\tilde{H}_1(\omega)P_1(\omega) + \tilde{F}_2(\omega)\tilde{H}_2(\omega)P_2(\omega) \right)$$

C. As in B, but now assume that $s_1(t)$ and $s_2(t)$ have a nonzero cross-spectrum $X(\omega)$.

Calculations are the same as in part B, but now $\lim_{T \rightarrow \infty} \frac{1}{T} \langle E(s_1, \omega) \overline{E(s_2, \omega)} \rangle = X(\omega)$ rather than zero. The formulae for the Fourier estimates are the same. So for the spectra,

$$R_1(\omega) = \lim_{T \rightarrow \infty} \frac{1}{T} \left\langle |E(r_1, \omega)|^2 \right\rangle =$$

$$\left| \tilde{Z}(\omega) \tilde{F}_1(\omega) \right|^2 \left(P_1(\omega) + \left| \tilde{F}_2(\omega) \tilde{H}_2(\omega) \right|^2 P_2(\omega) + \overline{\tilde{F}_2(\omega) \tilde{H}_2(\omega) X(\omega)} + \tilde{F}_2(\omega) \tilde{H}_2(\omega) \overline{X(\omega)} \right),$$

$$R_2(\omega) = \lim_{T \rightarrow \infty} \frac{1}{T} \left\langle |E(r_2, \omega)|^2 \right\rangle =$$

$$\left| \tilde{Z}(\omega) \tilde{F}_2(\omega) \right|^2 \left(P_2(\omega) + \left| \tilde{F}_1(\omega) \tilde{H}_1(\omega) \right|^2 P_1(\omega) + \overline{\tilde{F}_1(\omega) \tilde{H}_1(\omega) X(\omega)} + \tilde{F}_1(\omega) \tilde{H}_1(\omega) \overline{X(\omega)} \right),$$

And for the cross-spectra

$$\left\langle E(r_1, \omega) \overline{E(r_2, \omega)} \right\rangle =$$

$$\left| \tilde{Z}(\omega) \right|^2 \tilde{F}_1(\omega) \overline{\tilde{F}_2(\omega)} \left\langle \left(E(s_1, \omega) + \tilde{F}_2(\omega) \tilde{H}_2(\omega) E(s_2, \omega) \right) \overline{\left(E(s_2, \omega) + \tilde{F}_1(\omega) \tilde{H}_1(\omega) E(s_1, \omega) \right)} \right\rangle$$

$$= \left| \tilde{Z}(\omega) \right|^2 \tilde{F}_1(\omega) \overline{\tilde{F}_2(\omega)}$$

$$\left(\overline{\tilde{F}_1(\omega) \tilde{H}_1(\omega)} \left\langle |E(s_1, \omega)|^2 \right\rangle + \tilde{F}_2(\omega) \tilde{H}_2(\omega) \left\langle |E(s_2, \omega)|^2 \right\rangle + E(s_1, \omega) \overline{E(s_2, \omega)} + \overline{E(s_1, \omega) E(s_2, \omega)} \overline{\tilde{F}_1(\omega) \tilde{H}_1(\omega)} \tilde{F}_2(\omega) \tilde{H}_2(\omega) \right)$$

yielding

$$R_{12}(\omega) = \left| \tilde{Z}(\omega) \right|^2 \tilde{F}_1(\omega) \overline{\tilde{F}_2(\omega)}$$

$$\left(\overline{\tilde{F}_1(\omega) \tilde{H}_1(\omega)} P_1(\omega) + \tilde{F}_2(\omega) \tilde{H}_2(\omega) P_2(\omega) + X(\omega) + \overline{\tilde{F}_1(\omega) \tilde{H}_1(\omega)} \tilde{F}_2(\omega) \tilde{H}_2(\omega) \overline{X(\omega)} \right).$$

Q4. Graph Laplacians of composite graphs (2 parts, 1 point for each part)

A. Say G is a connected graph of size n_G whose graph Laplacian L_G has eigenvectors φ_i with eigenvalues λ_i , and H is a connected graph of size n_H whose graph Laplacian L_H has eigenvectors ψ_i with eigenvalues μ_i . For definiteness, take φ_1 to be the uniform eigenvector, i.e., the eigenvector composed of all 1's, for which $L_G\varphi_1 = 0$, and, similarly, for ψ_1 .

Consider the graph K of size $n_G + n_H$ consisting of all the vertices and edges in G and H , along with an edge from every vertex in G to every vertex in H . Find the eigenvectors and eigenvalues of the graph Laplacian of K .

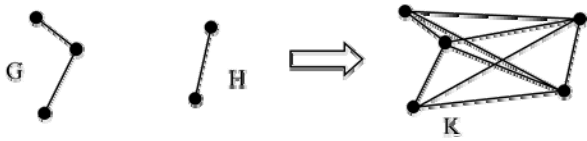

The graph Laplacian of K is a block matrix $L_K = \begin{pmatrix} L_G + n_H I & -1_{n_G \times n_H} \\ -1_{n_H \times n_G} & L_H + n_G I \end{pmatrix}$, where $1_{a \times b}$ is an $a \times b$ matrix

of 1's. (The on-diagonal elements are adjusted by the new connections between the G and H -components, and the off-diagonal blocks are filled with -1 's since every vertex of the G -subgraph is connected to every vertex of the H -subgraph). Consider one of the eigenvectors φ_j ($j \in \{2, 3, \dots, n_G\}$) of L_G that has a nonzero eigenvalue. Since it is orthogonal to the uniform eigenvector φ_1 (which has eigenvalue 0 and all entries equal to 1), the sum of its entries is 0. So $1_{1 \times n_G} \varphi_j = 0$. Now create a (column) vector ξ_j of length $n_G + n_H$ whose first n_G elements are some φ_j , and the remaining n_H elements are 0. Then

$$L_K \xi_j = \begin{pmatrix} L_G + n_H I & -1_{n_G \times n_H} \\ -1_{n_H \times n_G} & L_H + n_G I \end{pmatrix} \xi_j = \begin{pmatrix} L_G + n_H I & -1_{n_G \times n_H} \\ -1_{n_H \times n_G} & L_H + n_G I \end{pmatrix} \begin{pmatrix} \varphi_j \\ 0 \end{pmatrix} =$$

$$\begin{pmatrix} (L_G + n_H I)\varphi_j \\ -1_{n_H \times n_G} \varphi_j \end{pmatrix} = \begin{pmatrix} (\lambda_j + n_H)\varphi_j \\ 0 \end{pmatrix} = (\lambda_j + n_H)\xi_j$$

so ξ_j is an eigenvector of L_K with eigenvalue $n_H + \lambda_j$. This yields $n_G - 1$ such eigenvectors and their corresponding eigenvalues. The same argument, with the roles of G and H reversed, yields $n_H - 1$ eigenvectors, and their eigenvalues $n_G + \mu_j$.

Since we have found $(n_G - 1) + (n_H - 1) = n_G + n_H - 2$ eigenvectors and K is of size $n_G + n_H$, we need to find two more. For all of the eigenvectors found so far, their average over the G -subset and the H -subset is zero; the remaining eigenvectors will have to span the full space of functions on the graph. So we guess that they will be uniform but nonzero over the two subsets, i.e., make use of the two

eigenvectors φ_1 on G and ψ_1 on H that we haven't used yet. So we write $\zeta = \begin{pmatrix} g \mathbf{1}_{n_G \times 1} \\ h \mathbf{1}_{n_H \times 1} \end{pmatrix}$ and require

$$L_K \zeta = k \zeta. \text{ Since } L_G \mathbf{1}_{n_G \times 1} = 0 \text{ and } L_H \mathbf{1}_{n_H \times 1} = 0,$$

$$L_K \zeta = \begin{pmatrix} L_G + n_H I & -\mathbf{1}_{n_G \times n_H} \\ -\mathbf{1}_{n_H \times n_G} & L_H + n_G I \end{pmatrix} \begin{pmatrix} g \mathbf{1}_{n_G \times 1} \\ h \mathbf{1}_{n_H \times 1} \end{pmatrix} = \begin{pmatrix} g n_H \mathbf{1}_{n_G \times 1} - h \mathbf{1}_{n_G \times n_H} \mathbf{1}_{n_H \times 1} \\ -g \mathbf{1}_{n_H \times n_G} \mathbf{1}_{n_G \times 1} + h n_G \mathbf{1}_{n_H \times 1} \end{pmatrix} = \begin{pmatrix} (g n_H - h n_H) \mathbf{1}_{n_G \times 1} \\ (h n_G - g n_G) \mathbf{1}_{n_H \times 1} \end{pmatrix}. \text{ So for } \zeta \text{ to}$$

have eigenvalue k , we require

$$(g - h)n_H = kg$$

and

$$(h - g)n_G = kh.$$

This is equivalent to finding the eigenvectors $\begin{pmatrix} g \\ h \end{pmatrix}$ of a matrix $\begin{pmatrix} n_H & -n_H \\ -n_G & n_G \end{pmatrix}$ (non-symmetric, so we can't assume that they are orthogonal), and their eigenvalues k . We expect that one solution will be the uniform eigenvector for the composite graph, and will have $k = 0$. Indeed, $k = 0$, $g = h$ is a solution. We also expect a solution that sums to zero over the graph. For this to be the case, $g = n_H$ and $h = -n_G$ (or proportional), and $k = n_G + n_H$.

In sum, the eigenvectors and their eigenvalues are:
the uniform eigenvector, eigenvalue 0,

an eigenvector whose values on G and H are given by $\begin{pmatrix} g \\ h \end{pmatrix} = \begin{pmatrix} n_H \\ -n_G \end{pmatrix}$, eigenvalue $n_G + n_H$,

the $n_G - 1$ non-uniform eigenvectors on G , zero on H , eigenvalues $\lambda_j + n_H$, and

the $n_H - 1$ non-uniform eigenvectors on H , zero on G , eigenvalues $\mu_j + n_G$.

B. Say G is a connected graph of size n_G whose graph Laplacian L_G has eigenvectors φ_i with eigenvalues λ_i , and H is a connected graph of size n_H whose graph Laplacian L_H has eigenvectors ψ_i with eigenvalues μ_i . For definiteness, take φ_1 to be the uniform eigenvector, i.e., the eigenvector composed of all 1's, for which $L_G \varphi_1 = 0$, and, similarly, for ψ_1 .

Consider the graph B of size $n_G + n_H + 1$ consisting of all the vertices and edges in G and H , along with a new vertex P . There are edges from every vertex in G to P , and from every vertex in H to P . (If P is positioned between G and H , B is a "bowtie").

Find the eigenvectors and eigenvalues of the graph Laplacian of B .

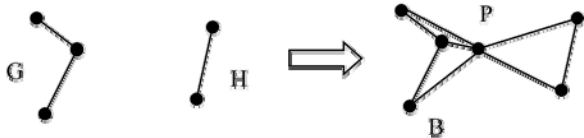

(Same general strategy as part B, see above for further details). The graph Laplacian of B is a block

$$\text{matrix } L_B = \begin{pmatrix} L_G + I & -1_{n_G \times 1} & 0 \\ -1_{1 \times n_G} & n_G + n_H & -1_{1 \times n_H} \\ 0 & -1_{n_H \times 1} & L_H + I \end{pmatrix} \quad (\text{The on-diagonal elements are adjusted by the new}$$

connections between the G and H -components, and the off-diagonal blocks have -1 's between the new vertex and the G - and H - subgraphs.) Consider one of the eigenvectors φ_j ($j \in \{2, 3, \dots, n_G\}$) of L_G that has a nonzero eigenvalue. Since it is orthogonal to the uniform eigenvector φ_1 (which has eigenvalue 0 and all entries equal to 1), the sum of its entries is 0. So $1_{1 \times n_G} \varphi_j = 0$. Now create a (column) vector ξ_j of length $n_G + n_H + 1$ whose first n_G elements are some φ_j , and the remaining $n_H + 1$ elements are 0. Then

$$L_B \xi_j = \begin{pmatrix} L_G + I & -1_{n_G \times 1} & 0 \\ -1_{1 \times n_G} & n_G + n_H & -1_{1 \times n_H} \\ 0 & -1_{n_H \times 1} & L_H + I \end{pmatrix} \xi_j = \begin{pmatrix} L_G + I & -1_{n_G \times 1} & 0 \\ -1_{1 \times n_G} & n_G + n_H & -1_{1 \times n_H} \\ 0 & -1_{n_H \times 1} & L_H + I \end{pmatrix} \begin{pmatrix} \varphi_j \\ 0 \\ 0 \end{pmatrix} = \begin{pmatrix} (L_G + I)\varphi_j \\ 0 \\ 0 \end{pmatrix} = (\lambda_j + 1)\xi_j,$$

so ξ_j is an eigenvector of L_B with eigenvalue $\lambda_j + 1$. This yields $n_G - 1$ such eigenvectors and their corresponding eigenvalues. The same argument, with the roles of G and H reversed, yields $n_H - 1$ eigenvectors, and their eigenvalues $\mu_j + 1$.

Since we have found $(n_G - 1) + (n_H - 1) = n_G + n_H - 2$ eigenvectors and the graph B is of size $n_G + n_H + 1$, we need to find three more. For all of the eigenvectors found so far, their average over the G -subset and the H -subset is zero; the remaining eigenvectors will have to span the full space of functions on the graph. So we guess that they will be uniform but nonzero over the two subsets, and

possibly also nonzero on the new point P as well. So we write $\zeta = \begin{pmatrix} g 1_{n_G \times 1} \\ p \\ h 1_{n_H \times 1} \end{pmatrix}$ and require $L_B \zeta = k \zeta$.

Since $L_G 1_{n_G \times 1} = 0$ and $L_H 1_{n_H \times 1} = 0$,

$$L_B \zeta = \begin{pmatrix} L_G + I & -1_{n_G \times 1} & 0 \\ -1_{1 \times n_G} & n_G + n_H & -1_{1 \times n_H} \\ 0 & -1_{n_H \times 1} & L_H + I \end{pmatrix} \begin{pmatrix} g 1_{n_G \times 1} \\ p \\ h 1_{n_H \times 1} \end{pmatrix} = \begin{pmatrix} g - p \\ -gn_G + (n_G + n_H)p - hn_H \\ h - p \end{pmatrix}. \quad \text{So for } \zeta \text{ to have}$$

eigenvalue k , we require

$$g - p = kg, \quad -gn_G + (n_G + n_H)p - hn_H = kp, \quad \text{and } h - p = kh.$$

This is equivalent to finding the eigenvectors $\begin{pmatrix} g \\ p \\ h \end{pmatrix}$ of a matrix $M = \begin{pmatrix} 1 & -1 & 0 \\ -n_G & n_G + n_H & -n_H \\ 0 & -1 & 1 \end{pmatrix}$, and their

eigenvalues k . (The matrix is non-symmetric, so we can't assume that the eigenvectors are orthogonal)

We expect that one solution will be the uniform eigenvector for the composite graph, and will have

$k = 0$. Indeed, $\begin{pmatrix} g \\ p \\ h \end{pmatrix} = \begin{pmatrix} 1 \\ 1 \\ 1 \end{pmatrix}$, eigenvalue $k = 0$ is a solution. The other two must sum to zero over the

graph.

One can find the characteristic equation of the above matrix, or, one can guess. A reasonable guess is

that there's an eigenvector that is 0 on the new vertex. This leads to $\begin{pmatrix} g \\ p \\ h \end{pmatrix} = \begin{pmatrix} n_H \\ 0 \\ -n_G \end{pmatrix}$, eigenvalue $k = 1$.

The trace of M , which is the sum of its eigenvalues, is $n_G + n_H + 2$, so the remaining eigenvalue must

be $n_G + n_H + 1$. This leads to $\begin{pmatrix} g \\ p \\ h \end{pmatrix} = \begin{pmatrix} -1 \\ n_G + n_H \\ -1 \end{pmatrix}$.

In sum, the eigenvectors and their eigenvalues are:

the uniform eigenvector, eigenvalue 0,

an eigenvector whose values on G , the new vertex p , and H are given by $\begin{pmatrix} g \\ p \\ h \end{pmatrix} = \begin{pmatrix} n_H \\ 0 \\ -n_G \end{pmatrix}$, eigenvalue 1

an eigenvector whose values on G , the new vertex p , and H are given by $\begin{pmatrix} g \\ p \\ h \end{pmatrix} = \begin{pmatrix} -1 \\ n_G + n_H \\ -1 \end{pmatrix}$, eigenvalue

$n_G + n_H + 1$

the $n_G - 1$ non-uniform eigenvectors on G , zero on H , eigenvalues $\lambda_j + 1$, and

the $n_H - 1$ non-uniform eigenvectors on H , zero on G , eigenvalues $\mu_j + 1$.

Q5. Graph Laplacians of bilaterally symmetric graphs (2 parts, 1 point for each part)

Say G is a connected graph of size n_G whose graph Laplacian L_G has eigenvectors φ_i with eigenvalues λ_i . For definiteness, take φ_1 to be the uniform eigenvector, i.e., the eigenvector composed of all 1's, for which $L_G\varphi_1 = 0$.

Now form a graph Y that consists of two copies of G , and, between these two copies, the corresponding nodes are connected. (Think of G as being the graph that represents connections within a hemisphere, and Y as being the graph that represents the two hemispheres, with their internal connections and callosal connections between the corresponding areas.)

There's an obvious two-element group $R = \{e, r\}$ that leaves Y invariant: the non-identity element of R interchanges the two components of Y .

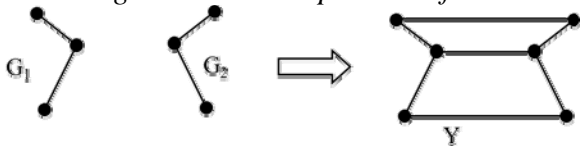

A. What does the action of R on Y imply about the eigenvectors of the graph Laplacian L_Y ?

R has two irreducible representations: the trivial one (in which the action of the non-identity element corresponds to multiplication by 1), and a non-trivial one (call it U), in which the action of the non-identity element corresponds to multiplication by -1 . This decomposes the space of functions on the graph Y into two components: a component in which R acts trivially, and a component in which R acts as U . Since R commutes with the Laplacian, every eigenvector of the Laplacian must lie within one of these two subspaces.

The first subspace is the set of functions whose values on the two copies of G are equal – so that interchanging them (i.e., applying r) has no effect. The second subspace is the set of functions whose values on the two copies of G are opposite in sign – so that applying r multiplies the functions by -1 .

B. Determine the eigenvectors and eigenvalues of the graph Laplacian L_Y .

The graph Laplacian of Y is a block matrix $L_Y = \begin{pmatrix} L_G + I & -I \\ -I & L_G + I \end{pmatrix}$. (The on-diagonal elements are

adjusted by the single new connections at each vertex that links the two components, and the off-diagonal blocks are filled with the negative of the identity matrix since each vertex of one component is connected to the corresponding vertex of the other component.)

Using the observation in a), consider a candidate eigenvector of the form $\begin{pmatrix} \varphi_i \\ \pm\varphi_i \end{pmatrix}$. Then

$$L_Y \begin{pmatrix} \varphi_i \\ \pm\varphi_i \end{pmatrix} = \begin{pmatrix} L_G + I & -I \\ -I & L_G + I \end{pmatrix} \begin{pmatrix} \varphi_i \\ \pm\varphi_i \end{pmatrix} = \begin{pmatrix} \lambda_i\varphi_i + \varphi_i \mp \varphi_i \\ -\varphi_i \pm \lambda_i\varphi_i \pm \varphi_i \end{pmatrix} = (\lambda_i + 1 \mp 1) \begin{pmatrix} \varphi_i \\ \pm\varphi_i \end{pmatrix}.$$

So each of these are eigenvectors: the n_G symmetric ones, which correspond to the trivial representation of R , are $\begin{pmatrix} \varphi_i \\ \varphi_i \end{pmatrix}$ and have eigenvalue λ_i ; the n_G antisymmetric ones, which correspond to the non-trivial representation of R , are $\begin{pmatrix} \varphi_i \\ -\varphi_i \end{pmatrix}$ and have eigenvalue $\lambda_i + 2$.

Q6: Community structure for a cyclic graph (Two parts, two points for the first part, one for the second)

Recall that the community structure of a graph consists of an assignment of each vertex i to a community c_i that maximizes the “quality function”

$$Q = \sum_{i,j} (a_{ij} - p_{ij}) \delta(c_i, c_j),$$

where the sum is over all distinct pairs of vertices $\{i, j\}$, $p_{ij} = \frac{d_i d_j}{2m}$, where m is the total number of edges, and d_i is the degree of the vertex i .

- A. For a cyclic graph G of size $n \geq 3$, find the community structure.
 B. For a linear graph G of size $n \geq 3$, find the community structure.

A. Say there are C classes, with n_c vertices in class c , and $\sum_{c=1}^C n_c = n$.

$$\text{We calculate } Q = \sum_{i,j} (a_{ij} - p_{ij}) \delta(c_i, c_j) = \sum_{i,j} a_{ij} \delta(c_i, c_j) - \sum_{i,j} p_{ij} \delta(c_i, c_j).$$

For the first term, $\sum_{i,j} a_{ij} \delta(c_i, c_j)$, this is a count of all vertices that are connected to each other and are in the same class. Since there are C classes, there must be at least C discontinuities (this occurs when each class occupies a contiguous block.) Thus the maximum of the first term is $n - C$, and this maximum can be achieved for any partition of the n vertices into C classes, as long as each class occupies a contiguous block.

To determine how to partition the vertices, we examine the second term, $\sum_{i,j} p_{ij} \delta(c_i, c_j)$ and attempt to minimize it. In a cyclic graph of size $n \geq 3$, each vertex has two neighbors, so $d_i = 2$. The total number of edges is n . So $p_{ij} = \frac{d_i d_j}{2m} = \frac{4}{2n} = \frac{2}{n}$, and $\sum_{i,j} p_{ij} \delta(c_i, c_j) = \frac{2}{n} \sum_{i,j} \delta(c_i, c_j)$.

Given that there are n_c vertices in class c , the number of pairs of vertices in class c that contribute to the sum is $\frac{n_c(n_c - 1)}{2}$, i.e., the number of ways of drawing two vertices from class c . So

$$\frac{2}{n} \sum_{i,j} \delta(c_i, c_j) = \frac{2}{n} \sum_{c=1}^C \frac{n_c(n_c - 1)}{2} = \frac{1}{n} \sum_{c=1}^C (n_c^2 - n_c) = \frac{1}{n} \sum_{c=1}^C n_c^2 - \frac{1}{n} \sum_{c=1}^C n_c = \frac{1}{n} \sum_{c=1}^C n_c^2 - \frac{n}{n} = \frac{1}{n} \sum_{c=1}^C n_c^2 - 1.$$

So we need to minimize $S = \sum_{c=1}^C n_c^2$ subject to the constraint that $\sum_{c=1}^C n_c = n$, and that the n_c 's are integers. Assuming that the minimum is $S_{\min}(C)$, we find the number of classes by maximizing

$$Q = \sum_{i,j} a_{ij} \delta(c_i, c_j) - \sum_{i,j} p_{ij} \delta(c_i, c_j) = n - C - \left(\frac{1}{n} S_{\min} - 1 \right)$$

Were it not for the integer constraint, the problem would be simple: the sum $S = \sum_{c=1}^C n_c^2$ is minimized

when each $n_c = n/C$, and so $S_{min} = C(n/C)^2 = n^2/C$. Then, we maximize Q :

$$Q(C) = n - C - \left(\frac{1}{n} \frac{n^2}{C} - 1 \right) = n - C - \frac{n}{C} + 1. \text{ An elementary argument (differentiating } Q(C) \text{ with}$$

respect to C) shows that this maximum is achieved at $C = \sqrt{n}$ and $n_c = n/C = \sqrt{n}$:

$$\frac{\partial Q}{\partial C} = \frac{\partial}{\partial C} \left(n - C - \frac{n}{C} + 1 \right) = -1 + \frac{n}{C^2}, \text{ so } \frac{\partial Q}{\partial C} = 0 \Rightarrow \frac{n}{C^2} = 1 \Rightarrow C = \sqrt{n}.$$

But this ignores the constraint that each of the n_c 's must be integers, so that (unless n is a perfect square), this minimum cannot be achieved. We show that at the minimum, no two of the n_c 's differ by more than 1 – for if they did, we can further reduce S by decreasing the larger n_c (say, replacing n_a by $n_a - 1$) and increasing the smaller n_c (say, replacing n_b by $n_b + 1$):

$$(n_a - 1)^2 + (n_b + 1)^2 = n_a^2 + n_b^2 + 2(n_b - n_a) + 2 < n_a^2 + n_b^2 \text{ if } n_a \geq n_b + 2.$$

So the minimum of S is achieved when the n_c 's have two adjacent values, say n_{low} and $n_{low} + 1$.

Moreover, we expect that the optimal value of n_{low} that maximizes Q is near \sqrt{n} .

Full credit awarded at this point.

A laborious but totally unrewarding argument shows that the values of n for which Q is maximized by at least one class of size $n_{low} = p$ and the remaining classes of size $n_{low} + 1$ is the range from $n = p(p-1) - 1$ to $n = p(p+1) - 2$, inclusive.

$$\text{B. For a linear graph, we again decompose } Q = \sum_{i,j} (a_{ij} - p_{ij}) \delta(c_i, c_j) = \sum_{i,j} a_{ij} \delta(c_i, c_j) - \sum_{i,j} p_{ij} \delta(c_i, c_j).$$

For the first term, $\sum_{i,j} a_{ij} \delta(c_i, c_j)$, this is a count of all vertices that are connected to each other and are

in the same class. Since there are C classes, there must be at least $C - 1$ discontinuities (this occurs when each class occupies a contiguous block.) Thus the maximum of the first term is $n - C + 1$, and, as is the case for the cyclic graph, this maximum can be achieved for any partition of the n vertices into C classes, as long as each class occupies a contiguous block.

For the second term, $p_{ij} = \frac{d_i d_j}{2m} = \frac{4}{2(n-1)} = \frac{2}{n-1}$ for any pair of vertices that does not include the

ends. For a pair of vertices at the ends, $p_{ij} = \frac{d_i d_j}{2m} = \frac{2}{2(n-1)} = \frac{1}{n-1}$. We can assume that in the

optimal community arrangement, (except for the case $n = 3$) that each end point and its neighbor are in

the same class, so $\sum_{i,j} p_{ij} \delta(c_i, c_j) = \frac{2}{n-1} \sum_{i,j} \delta(c_i, c_j) - \frac{1}{n-1} - \frac{1}{n-1} = \frac{2}{n-1} \left(\sum_{i,j} \delta(c_i, c_j) - 1 \right)$. So with

$S = \sum_{c=1}^c n_c^2$, this term is

$$\begin{aligned} \frac{2}{n-1} \left(\sum_{i,j} \delta(c_i, c_j) - 1 \right) &= \frac{2}{n-1} \left(\sum_{c=1}^c \frac{n_c(n_c-1)}{2} - 1 \right) = \frac{1}{n-1} \left(\sum_{c=1}^c n_c(n_c-1) \right) - \frac{2}{n-1} \\ &= \frac{1}{n-1} \sum_{c=1}^c n_c^2 - \frac{n}{n-1} - \frac{2}{n-1} = \frac{1}{n-1} \sum_{c=1}^c n_c^2 - \frac{n+2}{n-1} \end{aligned}$$

At this point, the arguments of part A still hold, so the minimum of S is achieved when the n_c 's have two adjacent values, say n_{low} and $n_{low} + 1$. Moreover, we expect that the optimal value of n_{low} that maximizes Q is near \sqrt{n} .

Full credit awarded at this point.

A laborious but totally unrewarding argument shows that the values of n for which Q is maximized by at least one class of size $n_{low} = p$ and the remaining classes of size $n_{low} + 1$ is the range from $n = p(p-1)$ to $n = p(p+1) - 1$, inclusive, for sufficiently large p .