

Exam, 2014-2015

Do a total of 30 points (more if you want, of course). Show your work!

Q1: 10 points (4 parts, 2 points each for the first two parts, 3 points each for the second two parts)

Q2: 10 points (11 parts, 1 point each, max credit 10 points)

Q3: 10 points (5 parts, 2 points each)

Q4 :12 points (6 parts, 2 points each)

Q1: Constructing a group representation based on cosets.

Let G be a finite group, and H a subgroup of G . Recall that the coset Hb is the set of all of the elements g of G that can be written in the form $g = h \circ b$, for some element h in H , and that the cosets constitute a partition of G into disjoint subsets.

Now consider the free vector space W on the cosets: that is, W be the vector space of functions from the cosets Hb to \mathbb{C} . Since W is a free vector space, it has a natural inner product, $\langle x, y \rangle = \sum_{\text{cosets } Hb} x(Hb) \overline{y(Hb)}$

For any function x in W and any element p of G , we define Q_p , a member of $\text{Hom}(W, W)$, as follows: Q_p takes x (a function on the cosets) to the $Q_p(x)$ (another function on the cosets) whose value at the coset Hb is given by $(Q_p(x))(Hb) = x(Hbp)$.

A. Show that this is a group representation.

B. What is its dimension (in terms of the sizes $\#(G)$ of G , and $\#(H)$ of H)?

C. Suppose further that G is commutative. What is the character of Q ?

D. (No longer supposing that G is commutative). Under what circumstances is Q irreducible?

Question 2. Permutation matrices and eigendecompositions

Consider an $n \times n$ cyclic permutation matrix M , defined by $m_{j,j+1} = 1$ for $1 \leq j \leq (n-1)$, $m_{n,1} = 1$, and otherwise

zero. Here, for $n = 5$: $M = \begin{pmatrix} 0 & 1 & 0 & 0 & 0 \\ 0 & 0 & 1 & 0 & 0 \\ 0 & 0 & 0 & 1 & 0 \\ 0 & 0 & 0 & 0 & 1 \\ 1 & 0 & 0 & 0 & 0 \end{pmatrix}$.

A. Is M unitary?

B. Is M self-adjoint?

C. What are the eigenvalues of M ?

D. What are the eigenvectors of M ?

E. Consider a matrix C , which is cyclic but with entries not necessarily drawn from $\{0,1\}$. (so it is not a permutation matrix). Specifically, $c_{j,k} = f_{k-j}$, where $k - j$ is interpreted mod n . For example, for $n = 5$,

$C = \begin{pmatrix} f_0 & f_1 & f_2 & f_3 & f_4 \\ f_4 & f_0 & f_1 & f_2 & f_3 \\ f_3 & f_4 & f_0 & f_1 & f_2 \\ f_2 & f_3 & f_4 & f_0 & f_1 \\ f_1 & f_2 & f_3 & f_4 & f_0 \end{pmatrix}$. Is C unitary?

F. Is C self-adjoint?

G. Does C commute with M ?

H. What are the eigenvectors of C ?

I. What are the eigenvalues of C ?

J. What are the eigenvalues of this matrix, which is a permutation matrix but not cyclic?

$P = \begin{pmatrix} 0 & 1 & 0 & 0 & 0 & 0 & 0 \\ 0 & 0 & 1 & 0 & 0 & 0 & 0 \\ 1 & 0 & 0 & 0 & 0 & 0 & 0 \\ 0 & 0 & 0 & 0 & 1 & 0 & 0 \\ 0 & 0 & 0 & 0 & 0 & 1 & 0 \\ 0 & 0 & 0 & 0 & 0 & 0 & 1 \\ 0 & 0 & 0 & 1 & 0 & 0 & 0 \end{pmatrix}$

K. What can you say about the eigenvalues of any permutation matrix of size $n \times n$?

Question 3. Transfer function and power spectrum in a simple physical system

Say an output, $x(t)$, is related to an input, $s(t)$ by $m \frac{d^2x}{dt^2} = s - kx - c \frac{dx}{dt}$. That is, the output x is the position of an object of mass m that is subject to a sum of three forces: the input signal s , a spring-like restoring force $-kx$, and a frictional force $-c \frac{dx}{dt}$.

A. Determine the transfer function that relates x to s .

B. Say s is white noise. What is the power spectrum of x ?

C and D. Under what circumstances does the power spectrum have a peak at a nonzero frequency? At what frequency is the peak?

E. Describe what happens if $c = 0$ (no friction).

Question 4. Coherence and network identification

Say $S_1(t)$ and $S_2(t)$ are noise sources with power spectra $P_{S_1}(\omega)$ and $P_{S_2}(\omega)$, not necessarily independent, which are connected to two observable outputs $R_1(t)$ and $R_2(t)$ by the following network, where L_{ij} are linear filters with transfer functions $\tilde{L}_{ij}(\omega)$.

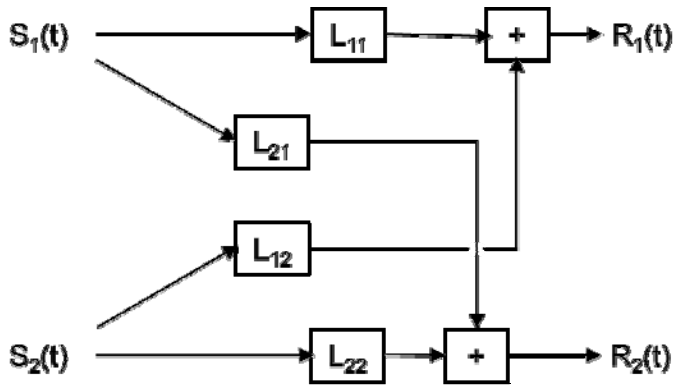

- Find the power spectra $P_{R_1}(\omega)$ and $P_{R_2}(\omega)$ of the outputs in terms of the power spectra $P_{S_i}(\omega)$ and cross-spectrum $P_{S_1, S_2}(\omega)$ of the inputs.
- Find the cross-spectrum of the outputs.
- C and D. Same as A and B, but for N independent noise sources fully connected to N observable outputs, rather than two.
- E. Define $S(\omega)$ as the “cross-spectral matrix” of S , i.e., the matrix whose elements are given by S

$$S_{ij}(\omega) = \begin{cases} P_{S_i}(\omega), & i = j \\ P_{S_i, S_j}(\omega), & i \neq j \end{cases}, \text{ and similarly for } R. \text{ Further define } \tilde{L}(\omega) \text{ as the matrix of transfer functions } \tilde{L}_{ij}(\omega).$$

Write a concise expression for $S(\omega)$ in terms of $R(\omega)$ and $\tilde{L}(\omega)$.

- F. Now say we know that each of the noise inputs are independent, and have a flat power spectrum, specifically, that $S(\omega) = I$. Can we deduce the matrix $\tilde{L}(\omega)$ from the matrix $R(\omega)$? Why or why not?