

## METHODS & DESIGNS

# A two-dimensional computer-controlled visual stimulator

NORMAN MILKMAN, GARY SCHICK, MICHELANGELO ROSSETTO,  
FLOYD RATLIFF, ROBERT SHAPLEY, and JONATHAN VICTOR  
*Rockefeller University, New York, New York 10021*

A computer-controlled instrument that creates complex two-dimensional patterns on a CRT monitor is described. These patterns are used to elicit visual evoked responses. Patterns are produced on a raster that is rotatable about its center. It is possible to assign to arbitrary regions in the raster any of four independent one-dimensional spatial-temporal functions. For each spatial-temporal function, the experimenter can select an arbitrary spatial profile, the spatial frequency of the profile, the starting phase of the profile, the temporal function, and the depth of modulation.

We are presently engaged in a project to bridge a gap between basic research on the neurophysiology of vision and clinical research on visual disorders (Ratliff, Victor, & Shapley, 1978). Over a period spanning many years, efforts in this laboratory had been devoted exclusively to basic research. During the early years of that period, visual stimuli consisted of small spots of light that could be turned on and off for predetermined time intervals. Electronic timers controlled electromagnetic shutters that could interrupt light beams emanating from an incandescent light source. These beams were imaged onto individual photoreceptors of the horseshoe crab, *Limulus*. Methods such as these, although considered primitive today, led to the advanced steady-state theory of excitation and inhibition in *Limulus* (Hartline & Ratliff, 1958). In later years, to obtain the temporal transfer function of eccentric cells in *Limulus*, glow modulator tubes that could be sinusoidally modulated replaced the incandescent light source (Ratliff, Knight, Dodge, & Hartline, 1974). Soon thereafter, it became clear that in order to characterize the system under study more fully, a complex spatial-temporal stimulus was required. This led to our development of visual stimulators that produce patterns on a cathode-ray tube (CRT). These patterns consist of flashing or drifting sinusoidal gratings and bars at arbitrary orientations (Milkman, Shapley, & Schick, 1978; Shapley & Rossetto, 1976). Such patterns were found useful in studying spatial and temporal interactions in the retina and central visual pathways (Hochstein & Shapley, 1976a, 1976b; Shapley & Gordon, 1978; Shapley & Victor, 1978, 1979; Snyder & Shapley, 1979; So & Shapley, 1979; Victor, Shapley, & Knight, 1977). Although still in use, these visual

This work was supported by Grant EY 02439 from the National Eye Institute, NIH.

stimulators are limited because they create only one-dimensional visual patterns. Two-dimensional spatial configurations are needed to match the configurations of the network under study.

For our current project, we wanted an instrument that could produce two-dimensional spatiotemporal patterns. We wanted the ability to specify two or more spatial-temporal functions within prescribed regions. Patterns of special interest are circular patterns with concentric annuli and checkerboard patterns with arbitrary-sized checks. Circular patterns closely match the receptive fields of a variety of neurons in the visual pathway. Their use maximizes the signal-to-noise ratio of the visual response. Checkerboard patterns are capable of eliciting strong visual evoked responses. We want to see how visual acuity correlates with check size in the evoked response. To meet the stated requirements and to anticipate future needs, we have designed and developed a computer-based instrument that can produce a large variety of spatiotemporal patterns of desired complexity. This paper describes the plan of the instrument. First, a rather broad overview of its pattern-producing capabilities is presented. Then the design strategy is indicated. Then, by means of discussions of block diagrams of the instrument, we will show how these capabilities arise.

### OVERVIEW

This instrument, with the aid of a computer, creates complex two-dimensional patterns on a CRT monitor such as the Tektronix 608. Patterns are produced on a raster that is rotatable about its center. It is possible to assign to arbitrary regions in the raster any of four independent one-dimensional spatial-temporal functions. Figure 1 illustrates the rotational and two-dimensional

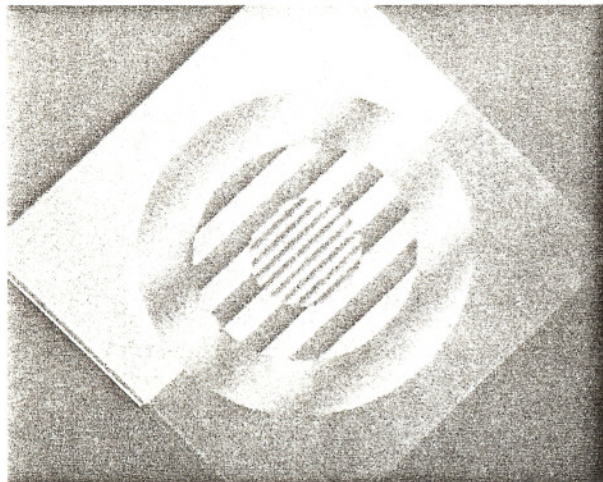

Figure 1. The rotational and two-dimensional spatial properties of the instrument are illustrated. The raster rotated at 45 deg contains four regions, each assigned to a different spatial-temporal function. The outermost region contains a square-wave profile of one cycle. The outer annulus contains a four-cycle sine-wave profile. The inner annulus contains a five-cycle square-wave profile, and the circle contains a nine-cycle sine-wave profile.

spatial properties of the instrument. A Polaroid snapshot of the face of the CRT shows the raster rotated at 45 deg, containing four regions, each of which encompasses a different spatial-temporal function. The regions consist of a central circle, two annuli, and an outer region. The outer region contains an intensity profile of one cycle of a square wave. The outer annulus contains an intensity profile of four cycles of a sine wave. The inner annulus shows approximately five cycles of a square wave, and the circle contains roughly nine cycles of a sine wave. Figure 2 demonstrates the ability to create a large number of regions. This photograph shows 1,024 regions distributed between two spatial-temporal functions in a 32 by 32 checkerboard array. As many as 65,536 regions are possible.

Photographs can show only static conditions. However, dynamic patterns such as drifting gratings and contrast-reversal gratings can be produced independently by each spatial-temporal function in our instrument. For example, in Figure 1, the square-wave gratings in the outer region and inner annulus can be made to drift from left to right, and the sinusoidal gratings in the outer annulus and circle can be made to drift from right to left. Moreover, the drift velocities for each spatial-temporal function can all be different. Instead of drifting patterns, contrast-reversal patterns can be produced in all four regions, with each region being temporally modulated by a different function. Alternatively, drifting patterns can be assigned to some regions and contrast-reversal patterns to others. It is also possible to produce drifting contrast-reversal patterns within specified regions. This flexibility is possible

because for each spatial-temporal function, the experimenter can set the following parameters within the instrument: (1) arbitrary regions in the plane to which the spatial-temporal function is assigned, (2) the type of spatial profile, (3) the spatial frequency of the spatial profile, (4) the starting spatial phase of the profile, (5) the type of temporal function, and (6) the overall depth of intensity modulation. Clearly, the variety of patterns that can be produced boggles the mind.

## DESIGN STRATEGY

The basic strategy is to create a television-type raster on a CRT in which, within specifiable regions on the raster, we can produce any of four one-dimensional spatial-temporal functions. This raster differs from an actual TV raster in two respects. First, it has a frame rate that is approximately an order of magnitude greater (270 Hz vs. 30 Hz). This permits us to probe the visual system in a significant temporal frequency region that TV rates fail to include. Second, the raster is rotatable. This feature permits us to probe for direction and orientation selectivity of visual neurons.

Specifying regions on the raster requires the capability to define these regions in two dimensions. Since the raster is produced as a rectangular plane, rectangular coordinates are used (X,Y) to specify regions. A raster of 256 lines is generated from time intervals provided by two counters counting 20-MHz clock ticks. The count in the first counter defines the position of a segment in a line containing 256 segments. The count in the second counter defines the position of a line in a 256-line raster. Thus the X coordinate is given by the line number and the Y coordinate is given by the segment number. The 256 line by 256 segment coordinates

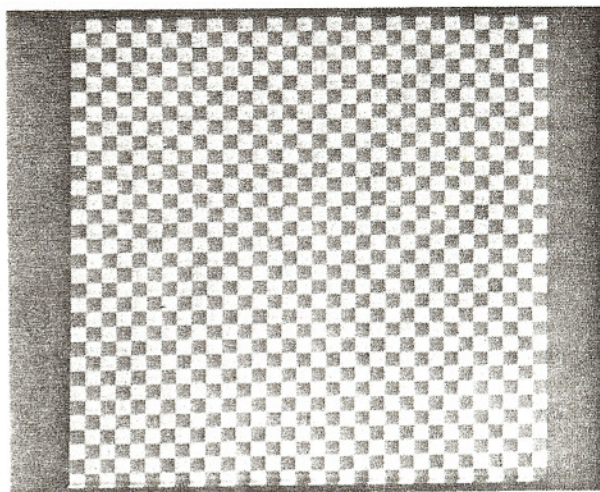

Figure 2. The ability to generate a large number of regions is demonstrated. The figure shows 1,024 regions distributed between two spatial-temporal functions in a 32 by 32 checkerboard array.

define the positions of 65,536 picture elements (pixels) in the plane. The idea is to provide a means by which each and every pixel can be assigned to any of four spatial-temporal functions. The assignments are provided by a memory bit map that contains a 2-bit code for each of 65,536 pixels. In each frame, the CRT beam traverses all pixels. As the beam moves from one pixel to the next, a unique 2-bit code supplied by the bit map causes a fast electronic switch to select the appropriate spatial-temporal function. In this way, the memory bit map enables us to map arbitrary regions on the raster in which desired spatial-temporal functions are selected.

## DIAGRAMS

### Overall Block Diagram

Figure 3 shows the overall block diagram of the instrument. There are nine blocks including the four spatial-temporal functions, which are identical. We briefly describe the six separable functions and then treat each in more detail.

The master timing circuits produce timing signals that synchronize the generation of a 256-line raster with the intensity modulation produced on it. The raster generator produces the X and Y signals to drive the CRT. It creates a 256-line raster that is rotatable about its center. The onset and termination of each line is derived from timing signals delivered by the master timing circuits. The raster rotation angle is specified by a computer.

The Z input to the CRT is provided by the Z switch.

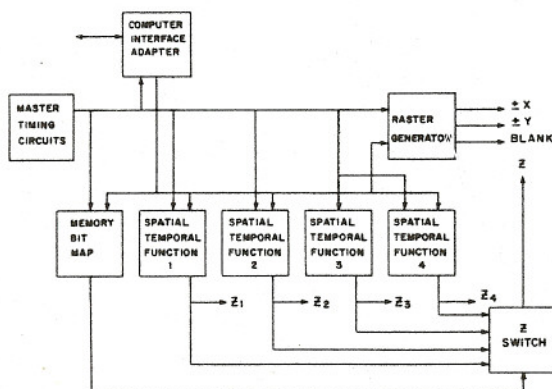

Figure 3. Block diagram of the instrument. The instrument comprises four spatial-temporal functions, a memory bit map, a fast analog Z switch, a raster generator, master timing circuits, and a computer interface adapter. The adapter distributes the computer-generated parameters to the instrument. Master timing circuits synchronize the generation of the raster with the intensity modulation produced on it. The raster generator provides a 256-line rotatable raster. The memory bit map assigns one of four spatial-temporal functions to each of 65,536 pixels in the raster by controlling the Z switch that selects the appropriate spatial-temporal function.

It selects one of four independent spatial-temporal functions in accordance with a 2-bit code provided by the memory bit map. For each line of the raster, the memory bit map produces a stream of 256 2-bit codes evenly spaced in time. The memory bit map holds 65,536 2-bit codes that assign each pixel in the raster to the appropriate spatial-temporal function. These codes are provided by a computer. Their function is to allocate regions on the raster to particular spatial-temporal functions.

Each spatial-temporal function is a one-dimensional intensity function. It consists of the product of three elements. One element is a spatial function. A second is a temporal function, and the third is a depth of modulation function. The spatial function is a line function that is synchronized to the line generation clock of the raster. Hence it maintains a given intensity for the duration of a line interval. Spatial parameters such as spatial profiles and spatial frequencies are provided by a computer. The temporal function is a frame function. It is an arbitrary function supplied by a computer that maintains a given value for the duration of a frame. A frame is the period required to produce a raster of 256 lines. The depth of modulation is a function that determines the minimum and maximum values of intensity produced by a spatial-temporal function. It, too, is supplied by a computer. Typically, its value is held constant for the experiment's duration. Each spatial-temporal function is brought to the Z switch available to be used in two-dimensional displays. Also, each is made available to provide one-dimensional displays to auxiliary CRTs.

The computer interface adapter transmits information between an interface to a computer and the instrument. Data requests to a computer are generated by this device. It distributes information received (rotation angle, spatial-temporal parameters, and bit map configuration) along an instrument bus containing address lines, data lines, and control lines. The raster generator, memory bit map, and spatial-temporal functions contain address decoders that enable each function to receive information intended for its use.

### Master Timing Block Diagram

Figure 4 shows the block diagram of the master timing circuits. These circuits consist essentially of two scale-of-272 cascaded counters being driven from a 20-megacycle crystal oscillator. The first scale-of-272 counter comprises the first two 4-bit counters and the line flip-flop. The waveform labeled "line" is produced as follows. Between Counts 0 and 255, the line flip-flop remains reset, and between Counts 256 and 271, it is set. In the time interval spanning Times 0-255, which takes 12.8 microsec, a line is produced in the raster. In the time interval spanning Times 255-272, which takes 800 nsec, the line is reset and a blanking signal is sent to the CRT.

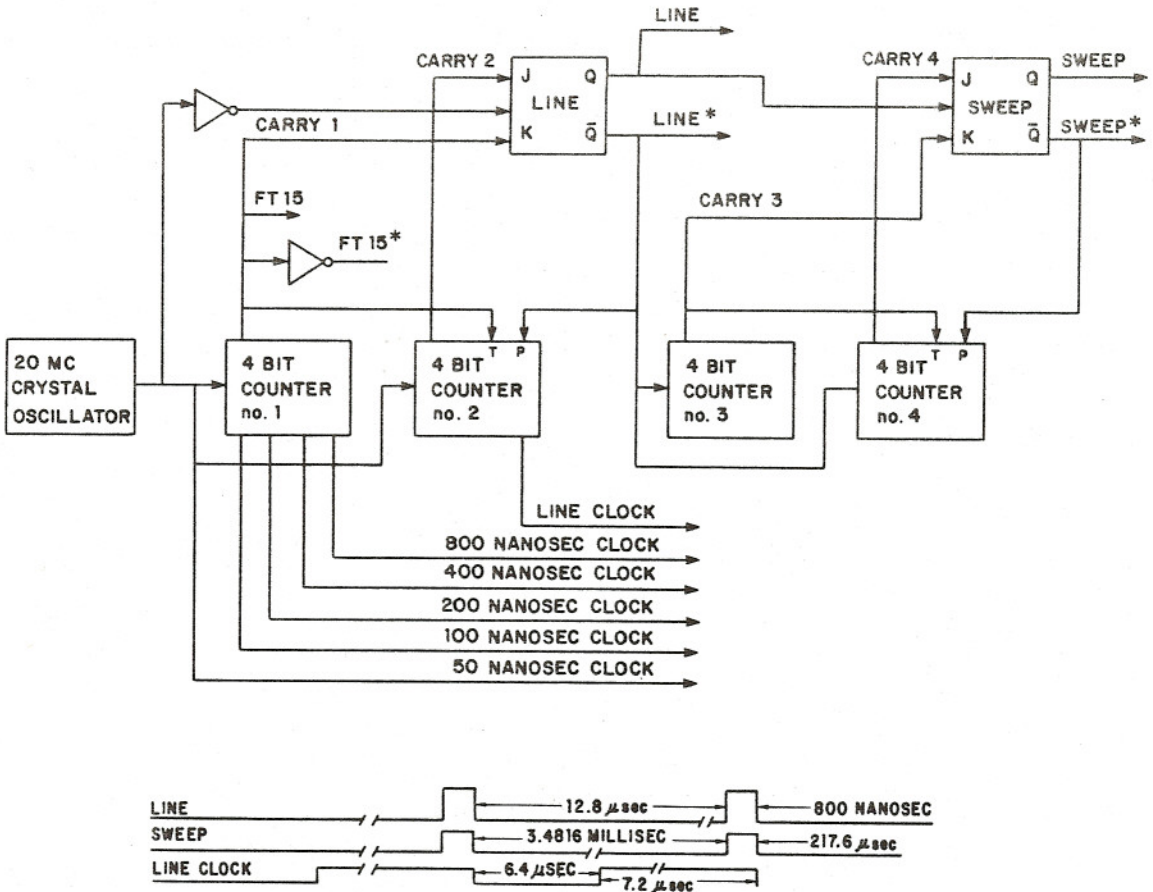

Figure 4. Master timing block diagram. The master timing circuits provide the timing signals required for synchronizing the raster generator with the modulation produced on it. The clocked signals are derived from a 20-MHz crystal oscillator driving two scale-of-272 cascaded counters.

The second scale-of-272 counter driven by the line clock comprises the second pair of 4-bit counters and the sweep flip-flop. Its function is to count 256 lines and then to produce a time interval for resetting the sweep, during which the screen is blanked. The sweep waveform shows that the time to generate 256 lines is 3.4816 msec, and the retrace time is 217.6 microsec. Thus a whole frame period is 3.6992 msec. It is during the reset period that updating of the spatial-temporal functions is done by the computer.

The crystal oscillator and the first 4-bit counter provide fast timing signals required by the memory map. The carry from the first 4-bit counter and its complement, labeled FT15 and FT15\*, respectively, are used to synchronize transfers from the computer to the memory map and spatial-temporal functions. The line clock drives the RAM address registers in the spatial-temporal functions, and the line, line\*, sweep, and sweep\* waveforms provide gating functions required by the raster generator, memory map, and spatial-temporal functions.

**Raster Generator Block Diagram**

The raster generator is designed to drive differential

X and Y inputs of the Tektronix 608 oscilloscope. It uses a configuration that enables it to combine the functions of raster generation and rotation. In the past, as described by Milkman et al. (1978) and Shapley and Rossetto (1976), rotation was accomplished by using four analog multipliers. This approach suffered from the bandwidth constraints of the multipliers and also from their inherent noise characteristics. In the present design, the raster generator creates a rotatable raster about its center by producing, during nonblanking intervals, four linear ramps of the following form:

$$Y+ = [(V\cos\theta)t/\tau_1] - (V\cos\theta/2) \quad 0 \leq t \leq \tau_1 \quad (1)$$

$$Y- = [(V\sin\theta)t/\tau_2] - (V\sin\theta/2) \quad 0 \leq t \leq \tau_2 \quad (2)$$

$$X+ = [(V\cos\theta)t/\tau_2] - (V\cos\theta/2) \quad 0 \leq t \leq \tau_2 \quad (3)$$

$$X- = -[(V\sin\theta)t/\tau_1] + (V\sin\theta/2) \quad 0 \leq t \leq \tau_1, \quad (4)$$

where  $\tau_1 = 12.8$  microsec and  $\tau_2 = 3.48$  msec. For any angle  $\theta$ , each ramp produces a voltage that is symmetrical with respect to 0 V. The magnitude of the

peak-to-peak swing for  $Y+$  and  $X+$  is  $|V\cos\theta|$ , and for  $Y-$  and  $X-$  it is  $|V\sin\theta|$ . The signature of the ramp slope depends on  $\theta$ . Since the ramps are linear and are derived from counters counting 20-megacycle clock ticks, the numbers in those counters provide a two-dimensional description of the beam position on the raster.

Figure 5 shows the block diagram of the raster generator.  $\sin\theta$  and  $\cos\theta$  are strobed into the corresponding  $\sin\theta$  and  $\cos\theta$  registers when the raster generator decoder recognizes its address. The multiplying digital-to-analog (D/A) converters and amplifiers produce  $\pm V\sin\theta$  and  $\pm V\cos\theta$ . These voltages are applied to the four ramp generating circuits. Each circuit behaves like an integrator when its associated electronic switch is open and approximately like an amplifier when the electronic switch is closed. Two of the switches are driven by line, and two are driven by sweep. The two driven by line remain open for 12.8 microsec and closed for 800 nsec. The two driven by sweep remain open for 3.4816 msec

and closed for 217.6 microsec. During the time the switches are closed, the ratio of  $R_1$  and  $R_2$  causes the circuits to reset to the values given by the right-hand terms on the right sides of the four equations. When the switches are open, the ramps corresponding to the left-hand terms are produced. The switches driven by line are in the integrators having time constants of  $RC$  chosen to equal 12.8 microsec. The other two integrators have time constants equal to  $272RC$ , or 3.4816 msec.

#### Memory Bit Map Logic Diagram

The function of the bit map logic is to produce 65,536 2-bit codes in synchrony with the generation of 65,536 pixels in the raster. The codes determine which spatial-temporal function is to be assigned to which pixel. While in principle it is possible to use two 65,536-bit shift registers to produce the codes, we chose instead to use two 4,096 word by 16 bit dynamic RAMs and two 16-bit shift registers. The computer has

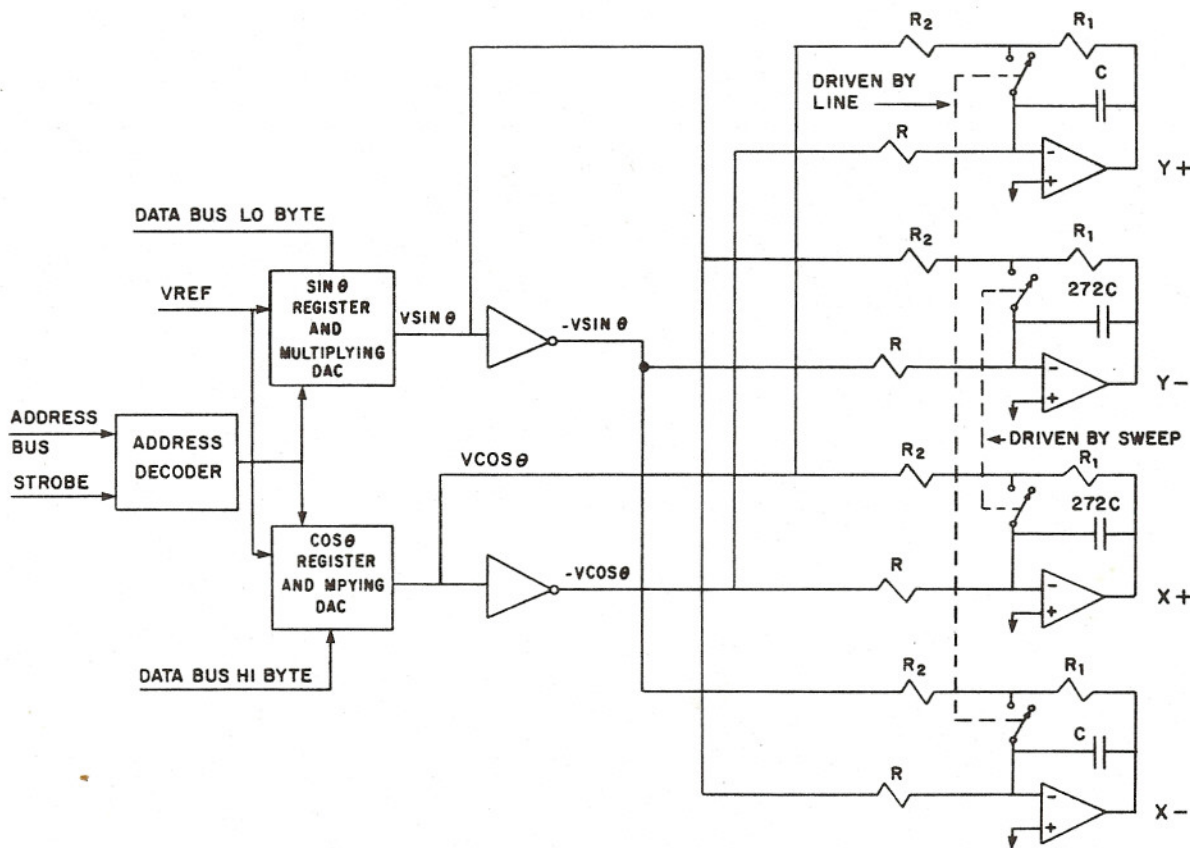

Figure 5. Raster generator. A 256-line rotatable raster is produced by the raster generator. The  $\sin$  and  $\cos$  of the rotation angle are provided by the computer. Voltages proportional to  $\pm\sin\theta$  and  $\pm\cos\theta$  are produced by the multiplying D/A converters and amplifiers. When the switches are open, linear ramps are produced by the four operational amplifiers. When the switches are closed, the ramps are reset to minus the value obtained at the end of the ramp. Thus rotation is provided around the center of the raster.

the responsibility of performing the transformation from memory address and bit number to pixel number in the raster.

Figure 6 shows the block diagram of the memory bit logic. The bit map data are written into locations in the two memory banks via the write data register and the write address register. The data are read out of the memory banks from locations specified by the read address register. Each frame, 4,096 word pairs are read from corresponding addresses in the two memory banks into two 16-bit parallel-to-serial shift registers. The shift clock is 20 MHz, so that every 50 nsec the least significant bits of the shift registers provide a 2-bit code that controls a fast analog switch in the Z switch logic.

Memory addressing is supplied by the read-write, row-column address multiplexer. The read-write (r/w sel) and

row-column (row/col sel) control signals are provided by the phasing circuits derived from master timing clocks. In each 800-nsec interval, the read and write addresses are multiplexed. The first 400-nsec interval is conditionally used for writing, and the second 400-nsec interval is unconditionally used for reading. Each 400-nsec interval contains shorter selected intervals for multiplexing row and column addresses. This feature enables 12-bit addressing to be accomplished using six address lines. In the last 50 nsec of each 800-nsec interval, the word pairs are read from corresponding addresses in the two memory banks via FT15\*.

The read address register can be initialized once each frame during the raster reset interval. It consists of three synchronous 4-bit counters that provide a 12-bit address to the read-write multiplexer. During non-

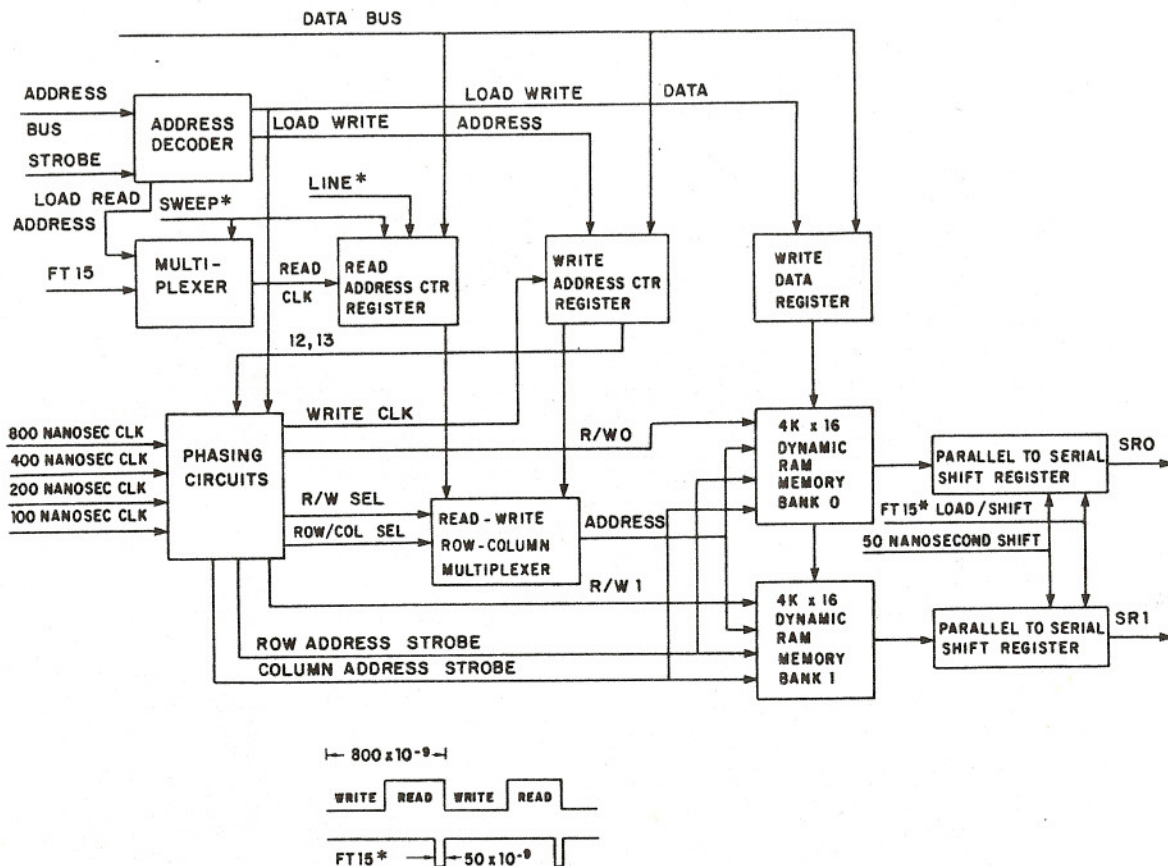

Figure 6. Memory bit map. The computer provides a 2-bit code for each of 65,536 pixels by filling up two 4,096 word by 16 bit dynamic memories. The locations are determined by the write address register, and their contents are provided by the data from the write data register. Each frame, 4,096 pairs of 16-bit words are read out of the RAMs from like locations in each memory bank into a pair of 16-bit parallel-to-serial shift registers. The addresses of the locations read are provided by the read address register. In each frame, the CRT beam traverses all the pixels. As the beam moves from one pixel to the next, a unique 2-bit code provided by the shift registers selects one of four possible independent spatial-temporal functions to modulate the beam.

blanking intervals, the counters are clocked by FT15, a pulse occurring every 800 nsec. The read address register sweeps through 4,096 addresses each frame. If the register is not initialized during the raster reset interval and no new information is written into the map, the regions allocated to the selected spatial-temporal functions will remain fixed from frame to frame. By loading a new initial address into the read address register at the end of each frame, the user can make the map drift with respect to the raster.

Writing into the map is controlled by the write address register and the write data register. Data can be written into the map at a maximum rate of once every 800 nsec. This is the limitation imposed by the hardware in the memory map logic. Maximum data writing rates are at present limited by transfer rates from the driving computer. The read address register, write address register, and write data register are all driven from the same data bus. The address decoder logic on board routes the data to the appropriate destination. To fill the map completely, the sequence of events is to first load the write address register with a 12-bit address and 2 bits of bank select control. Then data are asynchronously loaded into the write data register but synchronously written into the appropriate memory bank(s) during the 400-nsec interval provided for writing. At the end of the writing interval, the write address register is incremented. Thus it will take a maximum of 8,192 transfers to fill up both memory banks with completely new information. In principle, it is possible to regenerate the map in at most two frames. This provides an added dimension in pattern creation that at present is not being exploited, but which may prove to be a very powerful tool when the next generation of computers arrives.

### Z Logic Program

Figure 7 shows the logical block diagram of the Z switching circuits. Four spatial-temporal functions Z1 through Z4 are buffered by analog driver circuits. The buffered functions drive fast analog switches. These electronic circuits are represented as four single-pole single-throw switches with their poles tied together. The switch closures are digitally controlled by the decoder. Two inputs to the decoder are the shift register bits SR0 and SR1 from the memory bit map logic. The third input, labeled "Experiment Control," is provided by a bit from a control and status register in the computer interface adapter. This bit is used to keep all switches open prior to an experimental run. Thus analog ground will be presented to the Z input to the CRT at such times. At the start of an experimental run and for its duration, the switching functions will be controlled by SR0 and SR1. These 2 bits then determine which of the four Z input signals will provide intensity modulation for any given 50-nsec interval.

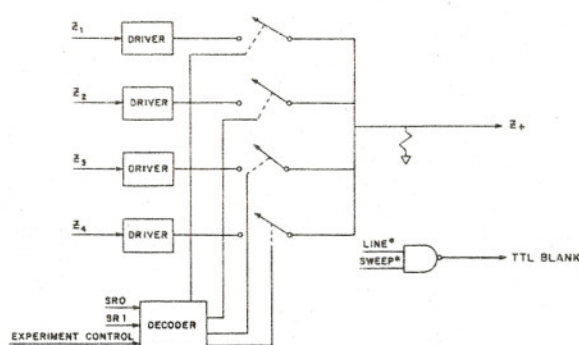

Figure 7. Z logic diagram. The decoder controls four fast electronic switches that select as modulation one of four spatial-temporal functions Z1-Z4 or analog ground. The experiment control function determines selection between analog ground or a spatial-temporal function. During experimental runs, shift register bits SR0 and SR1 determine which of the four spatial-temporal functions are selected. Blanking during line retraces and raster retraces are provided by the two-input NAND gate.

TTL blanking is provided to the Tektronix 608 scope during retrace of lines and retrace of the raster by the two-input NAND gate driven by line\* and sweep\*.

### Spatial-Temporal Function Block Diagram

Each of the spatial-temporal functions creates one-dimensional intensity patterns. Figure 8 shows the block diagram of a spatial-temporal function. Whenever the address decoder recognizes its address on the address bus, data are strobed into a 16-bit data register. The low byte of the data register drives a demultiplexer that enables one of many registers, all tied to an internal data bus driven by the high byte of the data register. Thus the address of any function on a spatial-temporal board is formed by a combination of the address on the address bus and the low data byte on the data bus. The internal bus gets data from the computer relating to RAM address, RAM contents, spatial frequency, initial spatial phase, temporal function, and depth of modulation. It requires two data transfers to deliver a byte of data to the 256-word RAM containing the spatial profile. One word delivers an address to the RAM address register, and the second supplies the contents for that address. Preparatory to an experiment, the computer fills the RAM with the desired spatial profile.

During the sweep, the RAM address register is clocked by the line clock. The RAM contents are transferred at Line\* time during the blanking interval on the scope. Thus once every line new RAM contents are transferred to the spatial multiplying D/A converter. Each clock cycle, a new RAM address is formed that equals the old address plus the spatial frequency. In one frame the RAM is accessed 256 times. This will result in overflowing the RAM address register exactly N times, where N is the spatial frequency. Therefore,

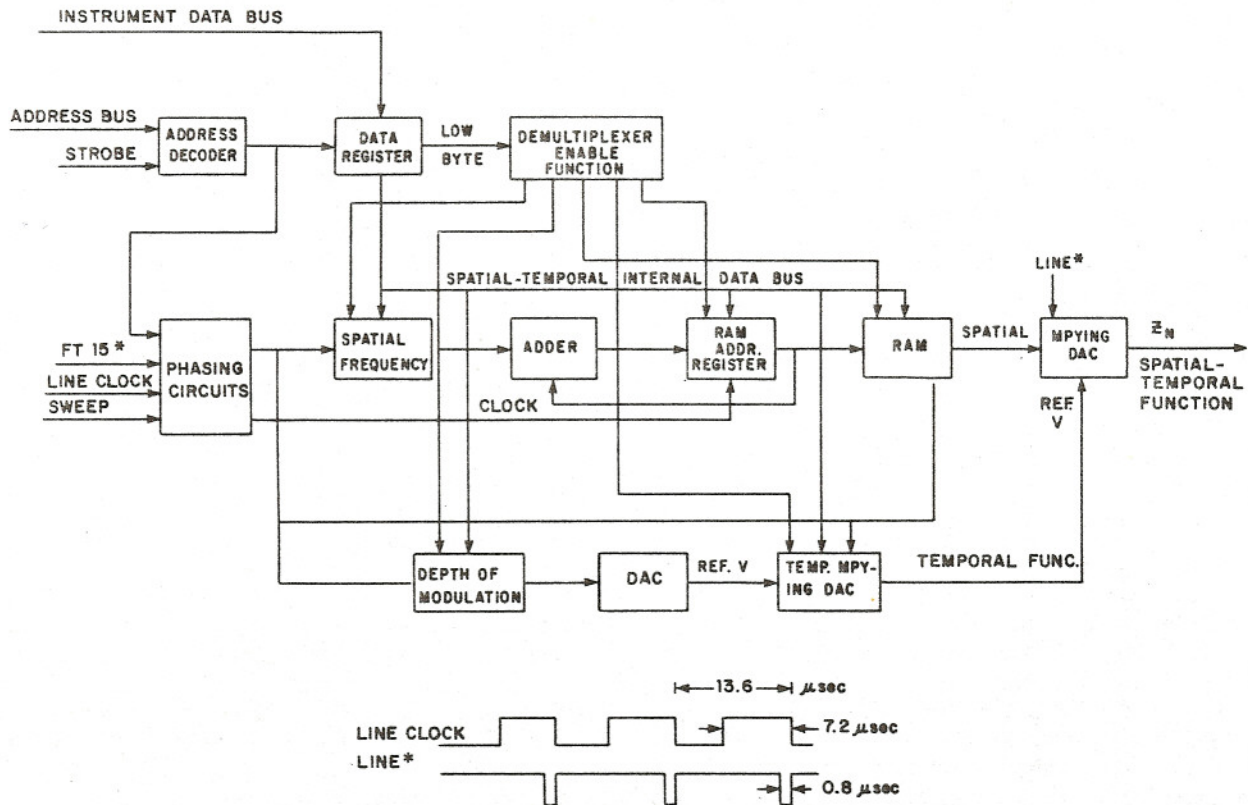

Figure 8. Spatial-temporal function. The computer supplies the intensity profile that resides in the RAM, the spatial frequency, the initial spatial address at the start of a frame, the depth of modulation, and the temporal function. In a typical experiment, the RAM, spatial frequency, and depth of modulation are initialized prior to an experimental run. During the run, at the end of each frame, the temporal function and/or the initial spatial address is updated. The RAM address register is clocked at the line generation rate. Hence the spatial function is a line function. The spatial-temporal output results from the triple product of depth of modulation, temporal function, and spatial function.

the number of cycles of spatial profiles per raster is determined by the spatial frequency. The reference voltage to the spatial multiplying D/A converter is provided by the box labeled "temporal multiplying dac," whose own reference voltage is the depth of modulation. The final output, then, represents the triple product of depth of modulation, temporal function, and spatial function. The computer updates the initial spatial address, spatial frequency, depth of modulation, or temporal function during the raster reset interval. Thus updating occurs when the screen is blanked, and hence transients are not seen. The experimenter can set a variety of spatial-temporal parameters, and thus he can produce a rich ensemble of spatial-temporal functions.

#### Computer Interface Adapter Block Diagram

The computer interface adapter has been designed for communication with a computer interface that has either direct memory access capability, interrupt capability, one-word transfers, or any combination of these

capabilities. Communication occurs over bidirectional data lines and unidirectional address and control lines. At present, the visual stimulator is under control of a DEC LSI-11/2 through a Computer Technology DMA-11 interface that has all of the communication facilities names above.

Figure 9 shows the block diagram of the computer interface adapter. Computer data information is received on a 16-bit bidirectional data bus, address information is received on a 3-bit address bus, and control information is received and returned over several control lines. Communication with the instrument is done via a 16-bit bidirectional data bus, a 3-bit address bus, one strobe line, and two control lines. An instrument control and status register determines the mode of communication. To illustrate communication, the way in which the memory bit map is filled is described below.

The first address on the instrument address bus is the memory map write address register passed directly from the computer interface bus through the address

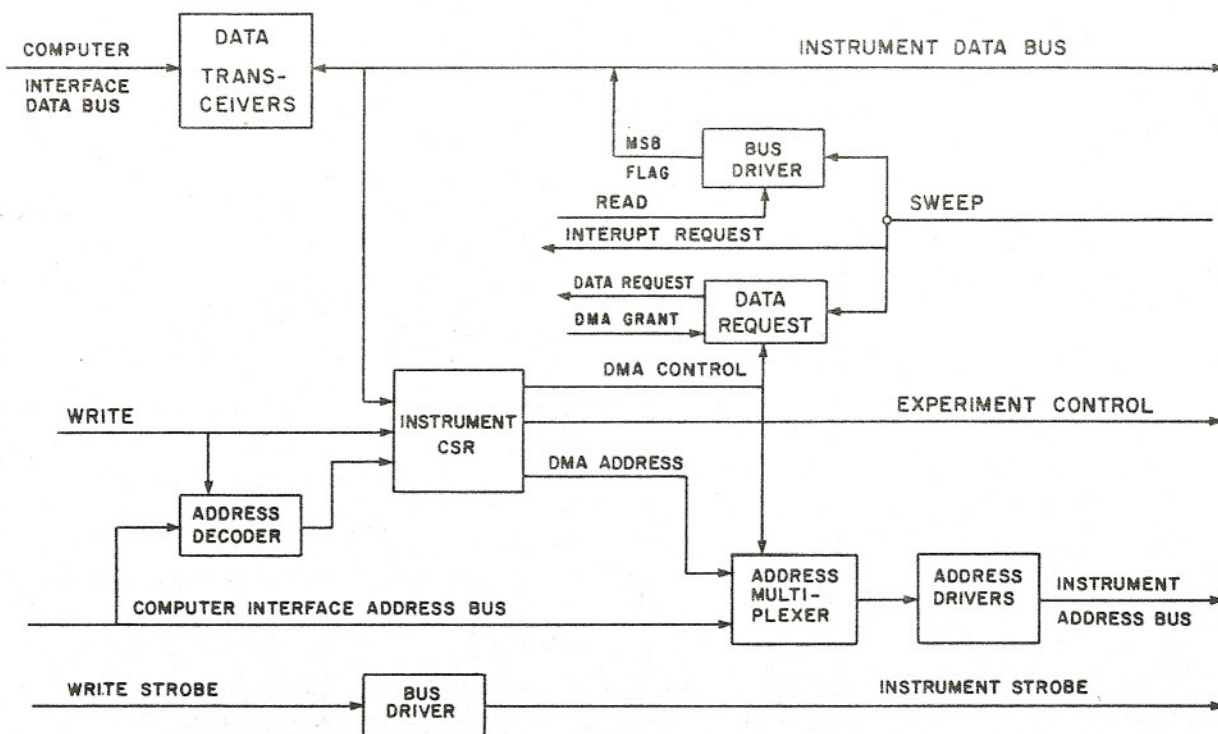

Figure 9. Computer interface adapter. Communication with the computer is accomplished through the interface adapter. The adapter receives information from the computer interface on 16-bit bidirectional data lines, three unidirectional address lines, and some control lines. Communication with the instrument is done over 16 bidirectional data lines, three address lines, one strobe line, and two control lines. The instrument CSR controls the mode of operation. During DMA transfers, the instrument address lines are provided by the CSR. Handshake logic controls the DMA transfers. During non-DMA transfers, the instrument address is supplied by the address lines from the computer interface. The address lines together with the strobe determines which function in the instrument is to receive the data on the data bus. The end-of-sweep signal is available to be used in an interrupt or flag mode to key the computer to update parameters.

multiplexer. Data sent from the computer will be strobed into the bit map write address register. Thus the first word address of one of the two 4K banks is initialized. Next, when the address decoder decodes its address, a word consisting of the write data register address and a DMA control bit is loaded by the write line to the instrument control switching register (CSR). The address multiplexer keeps this address on the instrument address bus until the DMA control bit is disabled. As soon as the DMA control bit is set, a data request is passed to the computer via the data request handshake logic. DMA grants, together with the data and write strobe, are then passed to the adapter that produces the instrument strobe that strobes the data to the write data register. The DMA grant turns off the data request. When the DMA grant turns off, the data request is turned back on. This procedure continues until the desired number of words is transferred. Then the CSR is cleared, inhibiting further DMA transfers. During this DMA operation, each time a word is transferred, internal logic in the memory bit map increments the write address register.

To provide a spatial profile to a spatial-temporal function, a similar procedure is followed, except that

the address held in the instrument CSR will be that of a spatial-temporal function and data requests will be confined to raster retrace intervals.

When non-DMA transfers take place, the address multiplexer selects the computer interface address bus. End-of-sweep signals are unconditionally generated interrupt requests that are ignored by the computer interface unless a CSR it contains enables interrupts. When an experimental run is to start, interrupts are enabled, and the experiment control bit in the instrument CSR is enabled. This permits the Z switch to be controlled from the shift register bits in the memory bit map. The computer updates information to the instrument in the end-of-sweep intervals.

## CONCLUSION

In recent years it has become evident that the study of information processing by neural networks in the visual system requires a more rigorous, more quantitative, and more comprehensive approach. To characterize the system fully, one needs to modulate the stimulus in space as well as in time. Further, one needs to vary the spatial configuration and orientation of the stimulus

to provide a best match for the configuration of the network under study. Moreover, the visual pathways are not homogeneous. Different channels may have quite different characteristics. Thus the need has arisen to have several different neighboring spatial-temporal patterns under control simultaneously. We have developed the instrument described here to provide the experimenter with what we believe to be unparalleled flexibility to select and create two-dimensional visual stimuli to probe the visual pathways for gaining an understanding of the underlying visual mechanisms.

## REFERENCES

- HARTLINE, H. K., & RATLIFF, F. Spatial summation of inhibitory influences in the eye of *Limulus*, and the mutual interaction of receptor units. *Journal of General Physiology*, 1958, **41**, 1049-1066.
- HOCHSTEIN, S., & SHAPLEY, R. Linear and nonlinear spatial subunits in Y cat retinal ganglion cells. *Journal of Physiology*, 1976, **262**, 265-284. (a)
- HOCHSTEIN, S., & SHAPLEY, R. Quantitative analysis of retinal ganglion cell classifications. *Journal of Physiology*, 1976, **262**, 237-264. (b)
- MILKMAN, N., SHAPLEY, R., & SCHICK, G. Experimental applications. A microcomputer-based visual stimulator. *Behavior Research Methods & Instrumentation*, 1978, **10**, 539-545.
- RATLIFF, F., KNIGHT, B. W., DODGE, F. A., JR., & HARTLINE, H. K. Fourier analysis of dynamics of excitation and inhibition in the eye of *Limulus*: Amplitude, phase, and distance. *Vision Research*, 1974, **14**, 1155-1168.
- RATLIFF, F., VICTOR, J. D., & SHAPLEY, R. M. Nonlinear analysis of visual evoked potentials in the human. *Journal of the Optical Society of America*, 1978, **68**, 1427.
- SHAPLEY, R. M., & GORDON, J. The eel retina: Ganglion cell classes and spatial mechanisms. *Journal of General Physiology*, 1978, **71**, 139-155.
- SHAPLEY, R., & ROSSETTO, M. An electronic visual stimulator. *Behavior Research Methods & Instrumentation*, 1976, **8**, 15-20.
- SHAPLEY, R. M., & VICTOR, J. D. The effects of contrast on the transfer properties of cat retinal ganglion cells. *Journal of Physiology*, 1979, **285**, 275-298.
- SHAPLEY, R. M., & VICTOR, J. D. Nonlinear spatial summation and the contrast gain control of the cat retina. *Journal of Physiology*, 1979, **290**, 141-163.
- SNYDER, A., & SHAPLEY, R. Deficits in the visual evoked potentials of cats as a result of visual deprivation. *Experimental Brain Research*, 1979, **37**, 73-86.
- SO, Y. T., & SHAPLEY, R. Spatial properties of X and Y cells in the lateral geniculate nucleus of the cat and conduction velocities of their inputs. *Experimental Brain Research*, 1979, **36**, 533-550.
- VICTOR, J. D., SHAPLEY, R. M., & KNIGHT, B. W. Nonlinear analysis of cat retinal ganglion cells in the frequency domain. *Proceedings of the National Academy of Science*, 1977, **74**, 3068-3072.

(Received for publication March 15, 1980;  
accepted April 8, 1980.)